

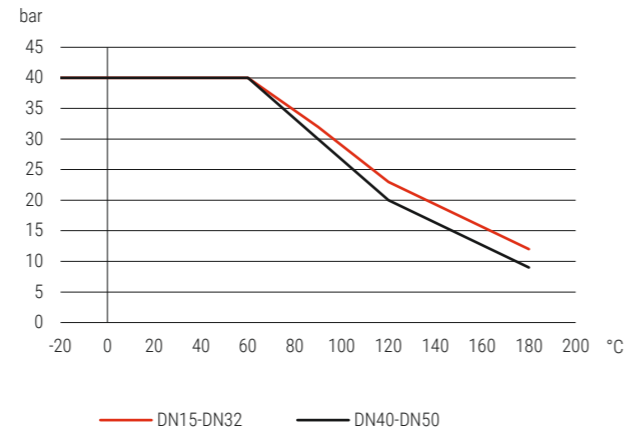

640ST-PN40 | Stahlguss | Hebelgriff | FI/FI/FI | T-Bohrung Aufbaufansch
640ST-PN40 | Carbon steel | Lever handle | FI/FI/FI | T-bore mounting flange
Druck-Temperatur-Diagramm pressure-temperature-diagram

Konstruktionsmerkmale

- Flanschanschlussmaße ANSI150 und ANSI300 auf Anfrage
- Flanschanschlussmaße nach DIN EN 1092-1 Dichtfläche B1
- Direktaufbau von Schwenkantrieben möglich
- Montageflansch nach DIN ISO 5211
- Negative Überdeckung
- Voller Durchgang

Standardtemperaturbereich

- 20°C bis + 180°C (abhängig von Betriebsdruck und Dichtsystem)
 Siehe Druck-Temperaturdiagramm

Zulassungstext

Einstufung nach PED Kategorie 3 PED 2014-68-EU, TA-Luft Zulassung nach VDI 2440

Verwendung

Wasser-Glykol-Mischungen, Heizungs-kreisläufe, Heizöl, Wasserdampf, Isocyanat, Wasser allgemein, Druckluft, Kraftstoffe, Öl, Thermoöl, Polyol, Tyfocor L, Tyfocor LS

Design features

- Flange connections ANSI150 and ANSI300 on request
- Flange connections acc. to DIN EN 1092-1 seal surface B1
- Direct mounting of actuators possible
- Mounting pad acc. to DIN ISO 5211
- Mixed during actuation
- Full port

Standard temperature range

- 20°C to + 180°C (depending on working pressure and sealing system)
 Take a look at the pressure-temperature-diagram

Approval text

Classification acc. to PED category 3 PED 2014-68-EU, TA-Air approval acc. to VDI 2440

Suitable for

Water-glycol mixture, Heating circuits, Heating oil, water vapour, Isocyanate, general water, Compressed air, Fuels, Oils, Thermo-oil, Polyol, Tyfocor L, Tyfocor LS

BESTELLBEISPIEL: Dreiwege-Flanschkuheln aus Stahlguss voller Durchgang T-Bohrung DN15 = 640ST-PN40-DN15 Artikel-Nr. 0020014011015
ORDERING EXAMPLE: 3-way flange ball valve of carbon steel full port design T-option DN15 = 640ST-PN40-DN15 item number 0020014011015

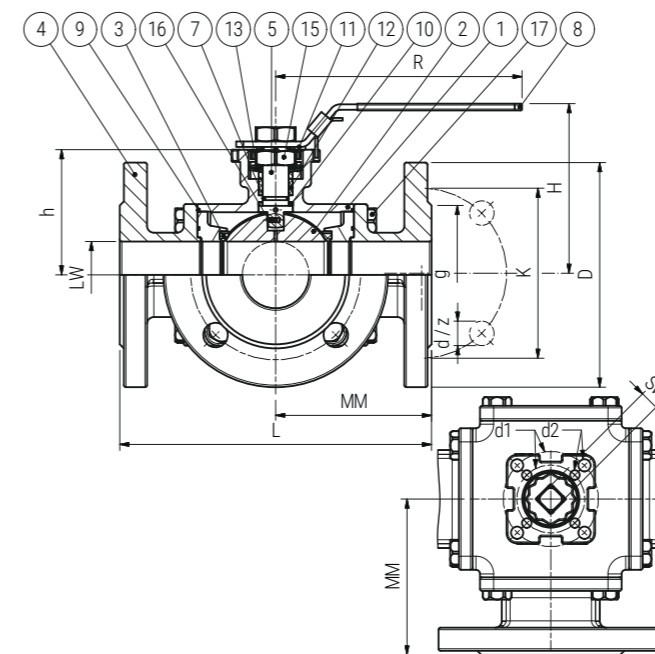
Maßskizze measured sketch

Materialtabelle materials grid

Nr. No.	Bezeichnung Description	Werkstoff Material	Materialbezeichnung Material description
1	Gehäuse Body	Stahlguss Cast steel	1.0619
2	Kugel Ball	Edelstahl Stainless steel	1.4308
3	Kugeldichtung Ball seal	PTFE TFM	-
4	Flansch / Nippel Flange / nipple	Stahlguss Cast steel	1.0619
5	Schaltwelle Stem	Edelstahl Stainless steel	1.4301
7	Spindeldichtung Spindle seal	FKM	-
8	Griff Handle	Edelstahl Stainless steel	1.4301
9	Gehäusedichtung Body seal	PTFE	-
10	Anlauftring Thrust washer	PTFE	-
11	Anschlagstift Stop pin	Edelstahl Stainless steel	1.4301
12	Packung Packing	PTFE	-
13	Tellerfeder Spring plate	Federstahl Spring steel	1.4310
15	Packungsmutter Packing nut	Edelstahl Stainless steel	1.4301
16	Federndes Druckstück Spring pressure piece	Edelstahl Stainless steel	1.4301
17	Sechskantschraube Bolt	Edelstahl Stainless steel	1.4301

Losbrechmomente breakaway torque

DN (mm)	PN0 (Nm)	PN7 (Nm)	PN16 (Nm)	PN40 (Nm)
15	8	8	8	8
20	12	12	12	12
25	18	18	18	20
32	30	30	32	37
40	40	40	45	50
50	60	60	70	80