

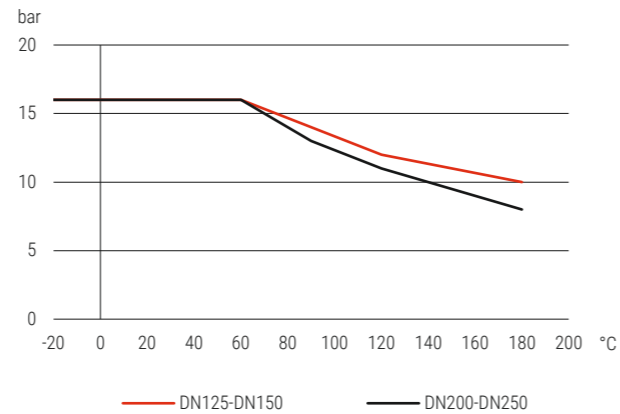

KSL77B | Hebelgriff | FI/FI | Kugel Grauguss
KSL77B | Lever handle | FI/FI | Ball grey cast iron

Druck-Temperatur-Diagramm pressure-temperature-diagram

Konstruktionsmerkmale

- Schwimmende Kugel
- Ausblässichere Schaltwelle
- Wartungsfrei
- Gekammerte Dichtung
- Montageflansch nach DIN ISO 5211
- Silikonfrei
- Fire Safe Design
- Voller Durchgang, DN250 reduzierter Durchgang
- Zweiteiliges Gehäuse mit Mitelflansch

Standardtemperaturbereich

- 20°C bis + 180°C (abhängig vom Betriebsdruck)
 Siehe Druck-Temperaturdiagramm

Zulassungstext

Einstufung nach PED Kategorie 3 PED 2014-68-EU, TA-Luft Zulassung nach DIN EN ISO 15848, LABS konform nach VDMA 24364

Verwendung

Öl, Thermoöl, Isocyanat, Druckluft, Kraftstoffe, Heizöl, Heizungskreisläufe, Wasser-Glykol-Mischungen, Polyol, Isocyanat, Wasser allgemein, Tyfocor L, Tyfocor LS

Design features

- Floating ball
- Blow out proved stem design
- Maintenance-free
- 3 side guided ball seals
- Mounting pad acc. to DIN ISO 5211
- Free of silicon
- Fire Safe Design
- Full port, DN250 reduced port
- Two-piece body with middle flange

Standard temperature range

- 20°C to + 180°C (depending on working pressure)
 Take a look at the pressure-temperature-diagram

Approval text

Classification acc. to PED category 3 PED 2014-68-EU, TA-Air approval acc. to DIN EN ISO 15848, LABS conformity acc. to VDMA 24364

Suitable for

Oils, Thermo-oil, Isocyanate, Compressed air, Fuels, Heating oil, Heating circuits, Water-glycol mixture, Polyol, Isocyanate, general water, Tyfocor L, Tyfocor LS

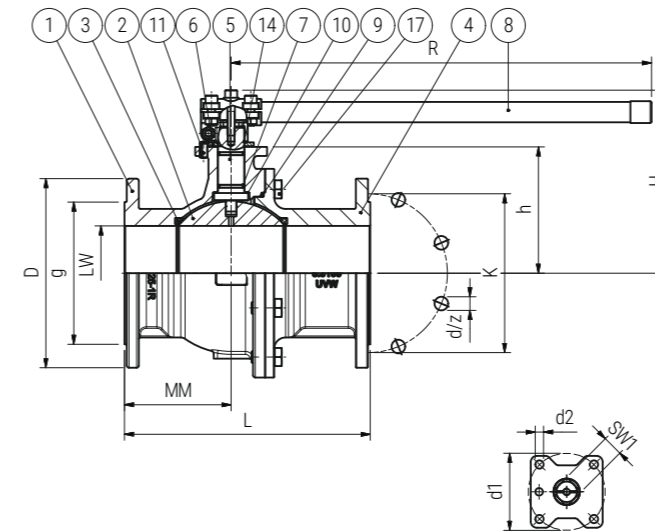
BESTELLBEISPIEL: Flansch-Kugelhahn Sphäroguss mit Graugusskugel DN125 = KSL77B-DN125 Artikel-Nr. 00V41295
ORDERING EXAMPLE: Flange ball valve of spheroidal graphite cast iron with grey cast iron ball DN125 = KSL77B-DN125 item number 00V41295
Maßskizze measured sketch

Materialtabelle materials grid

Nr. No.	Bezeichnung Description	Werkstoff Material	Materialbezeichnung Material description
1	Gehäuse Body	Sphäroguss Nodular cast iron	5.3105
2	Kugel Ball	Stahlguss verchromt Cast steel (chromed)	1.0503
3	Kugeldichtung Ball seal	PTFE	-
4	Flansch / Nippel Flange / nipple	Sphäroguss Nodular cast iron	5.3105
5	Schaltwelle Stern	Edelstahl Stainless steel	1.4104
6	Anschlagscheibe Stop plate	Stahl verzinkt Steel (zinc-plated)	-
7	Spindeldichtung Spindle seal	FKM	-
8	Griff Handle	Edelstahl Stainless steel	1.4301
9	Gehäusedichtung Body seal	FKM	-
10	Anlauftring Thrust washer	Polyamid Polyamide	-
11	Anschlagstift Stop pin	Stahl verzinkt Steel (zinc-plated)	-
14	Federring Clip ring	Federstahl Spring steel	-
17	Sechskantschraube Bolt	Stahl verzinkt Steel (zinc-plated)	8.8

Losbrechmomente breakaway torque

DN (mm)	PN0 (Nm)	PN7 (Nm)	PN16 (Nm)
125	90	100	120
150	120	150	170
200	250	270	300
250	250	270	300