



TAS22.FL

TAS22.FL BG

TAS22.FL | Stahl verzinkt | FI/FI  
TAS22.FL | Steel zinc plated | FI/FI

Druck-Verlust-Diagramm für Erdgas Pressure-loss diagram for natural gas

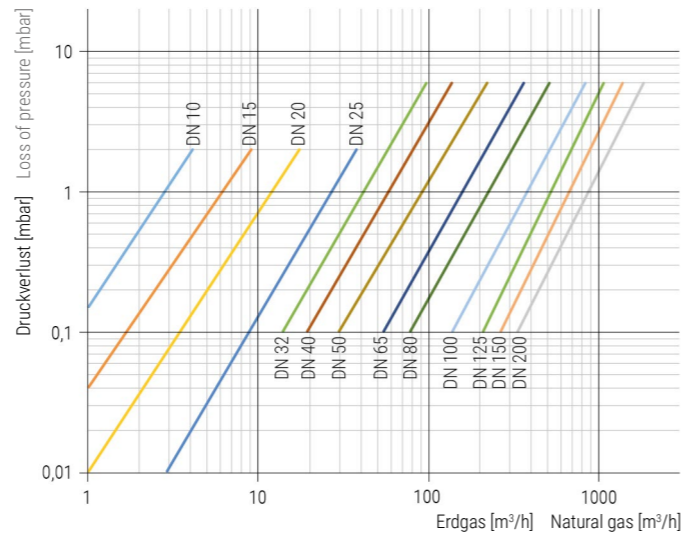
BESTELLBEISPIEL: TAE mit Flanschanschluss DN25 = TAS22.FL-DN25 Artikel-Nr. 01-210425  
ORDERING EXAMPLE: TAE with flange ends DN25 = TAS22.FL-DN25 item number 01-210425

Datentabelle data table

DN	PN	L	MM	D	K	g	z	d	Gewicht Weight (kg)	Artikel-Nr. Item number
(mm)	(bar)	(mm)	(mm)	(mm)	(mm)	(mm)		(mm)		
25	16	80	28	115	85	68	4	14	2,670	01-210425
32	16	90	35,3	140	100	78	4	18	3,860	02-222032
40	16	90	35,3	150	110	88	4	18	4,890	02-222040
50	16	110	35,3	165	125	102	4	18	6,800	02-222050

Maßskizze measured sketch

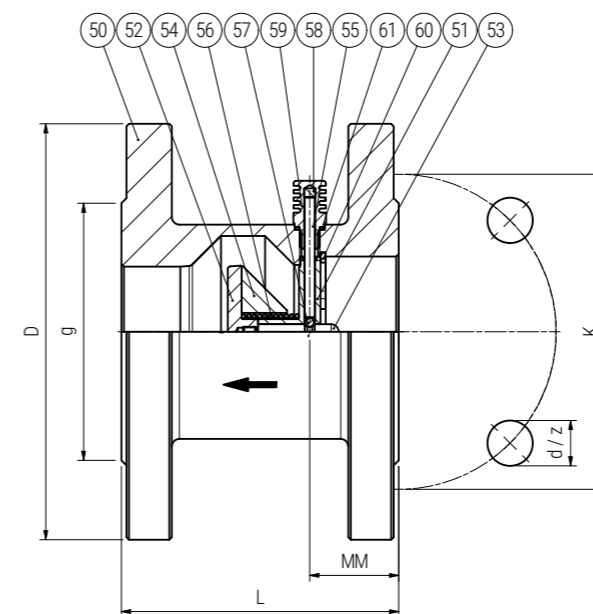

Materialtabelle materials grid

Nr. No.	Bezeichnung Description	Werkstoff Material	Materialbezeichnung Material description
50	Gehäuse Body	Stahl verzinkt Steel (zinc-plated)	1.0715
51	Stern Star	Messing Brass	CW614N
52	Schließkegel Closing cone	Edelstahl Stainless steel	1.4104
53	Führungsstift Guide pin	Edelstahl Stainless steel	1.4104
55	Auslösestift Release pin	Edelstahl Stainless steel	1.4301
56	Druckfeder Pressure spring	Federstahl Spring steel	1.4310
57	Kugel Ball	Edelstahl Stainless steel	1.4301
58	Lot Solder	Lot 95 Solder 95	-
59	Aussenfühler Temperature sensor	Stahl verzinkt Steel (zinc-plated)	1.0503
60	Sicherungsring Circlip	Federstahl Spring steel	-
61	Dichtring Seal ring	Kupfer Copper	-

2.1



## Konstruktionsmerkmale

- Thermisch auslösende Absperrvorrichtung (TAE) nach DVGW TRGI
- TAE bestehend aus Gehäuse mit integrierten Auslöseelementen und Schließkörper
- Mit Außenfühler
- Absperrrichtung gemäß Anforderungen aus DIN 3586
- Gehäuse aus Stahl verzinkt
- Korrosionsschutz unter Gasbeschaffenheit nach DVGW G260 ist sichergestellt
- Flanschanschlussmaße nach DIN EN 1092-1 Dichtfläche B1

## Standardtemperaturbereich

- 20°C bis + 60°C

## Technische Daten

- Auslösetemperatur: < 95°C ± 5K
- Auslösezeit: < 60 sek.
- Druckstufe: MOP5
- Therm. Belastbarkeit: ≤ 650°C
- Umgebungstemp. max.: ≤ 60°C

## Zulassungstext

DVGW Gas Zulassung nach DIN 3586, DVGW Zulassung nach Gasgeräteverordnung GAR EU-2016-426, DVGW Zulassung Gas thermisch bis 650°C belastbar, Einstufung nach PED Kategorie 3 PED 2014-68-EU

## Verwendung

Gase nach G260

## Design features

- Thermally released shut off device (TAE) acc. to DVGW TRGI
- TAE consisting of body with integrated release device and closing body
- With external sensor
- Shut off device acc. to the requirements of DIN 3586
- Steel body zinc plated
- Corrosion protection under gas quality acc. to DVGW G260 is ensured
- Flange connections acc. to DIN EN 1092-1 seal surface B1

## Standard temperature range

- 20°C to + 60°C

## Technical data

- Release temperature: < 95°C ± 5K
- Release time: < 60 sek.
- Pressure rating: MOP5
- Thermal rating: ≤ 650°C
- Max. ambient temp.: ≤ 60°C

## Approval text

DVGW gas approval acc. to DIN 3586, DVGW-approval acc. to gas appliance regulation GAR EU-2016-426, DVGW gas approval thermally resistant up to 650°C, Classification acc. to PED category 3 PED 2014-68-EU

## Suitable for

Gases acc. to G260



2.1

