

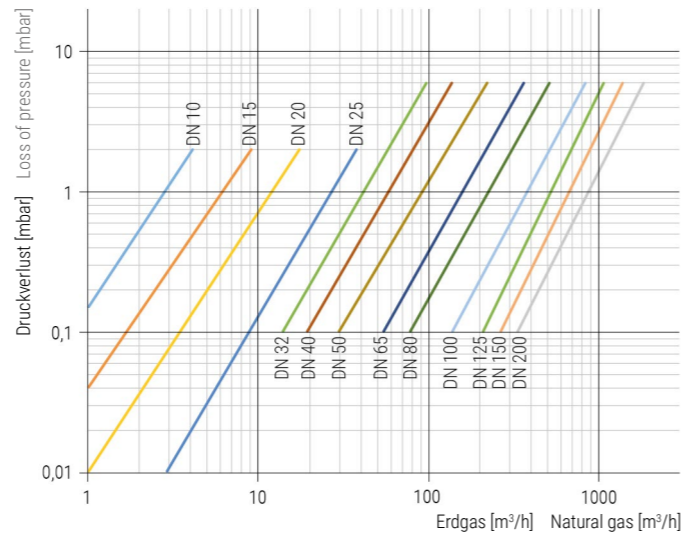

TAS21.0

TAS21.1

TAS21.1BG

**TAS21.1 | Stahl verzinkt | IG/AG**  
**TAS21.1 | Steel zinc plated | F/M****Druck-Verlust-Diagramm für Erdgas Pressure-loss diagram for natural gas****Konstruktionsmerkmale**

- Thermisch auslösende Absperrvorrichtung (TAE) nach DVGW TRGI
- TAE bestehend aus Gehäuse und Schmelzeinsatz (Kartusche)
- Absperrrichtung gemäß Anforderungen aus DIN 3586
- Gehäuse aus Stahl verzinkt
- Korrosionsschutz unter Gasbeschaffenheit nach DVGW G260 ist sichergestellt
- Gewinde nach DIN EN 10226-1

**Standardtemperaturbereich**

- 20°C bis + 60°C

**Technische Daten**

- Auslösetemperatur: < 95°C ± 5K
- Auslösezeit: < 60 sek.
- Druckstufe: MOP5
- Therm. Belastbarkeit: ≤ 650°C
- Umgebungstemp. max.: ≤ 60°C

**Zulassungstext**

DVGW Gas Zulassung nach DIN 3586, DVGW Zulassung nach Gasgeräteverordnung GAR EU-2016-426, DVGW Zulassung Gas thermisch bis 650°C belastbar, Einstufung nach PED Kategorie 0 PED 2014-68-EU

**Verwendung**

Gase nach G260

**Design features**

- Thermally released shut off device (TAE) acc. to DVGW TRGI
- TAE consisting of body and fusible cartridge
- Shut off device acc. to the requirements of DIN 3586
- Steel body zinc plated
- Corrosion protection under gas quality acc. to DVGW G260 is ensured
- Thread acc. to DIN EN 10266-1

**Standard temperature range**

- 20°C to + 60°C

**Technical data**

- Release temperature: < 95°C ± 5K
- Release time: < 60 sek.
- Pressure rating: MOP5
- Thermal rating: ≤ 650°C
- Max. ambient temp.: ≤ 60°C

**Approval text**

DVGW gas approval acc. to DIN 3586, DVGW-approval acc. to gas appliance regulation GAR EU-2016-426, DVGW gas approval thermally resistant up to 650°C, Classification acc. to PED category 0 PED 2014-68-EU

**Suitable for**

Gases acc. to G260



**BESTELLBEISPIEL: TAE Innengewinde/Außengewinde Größe 1/2" = TAS21.1 - 1/2" Artikel-Nr. 01-210015**  
**ORDERING EXAMPLE: TAE female/male thread size 1/2" = TAS21.1 - 1/2" item number 01-210015**

**Datentabelle data table**

D1	D2	DN	PN	L	SW	Gewicht Weight (kg)	Artikel-Nr. Item number
		(mm)	(bar)	(mm)	(mm)		
Rp 1/2"	R 1/2"	15	5	46	27	0,100	01-210015
Rp 3/4"	R 3/4"	20	5	49	32	0,130	01-210020
Rp 1"	R 1"	25	5	55,5	41	0,259	01-210025

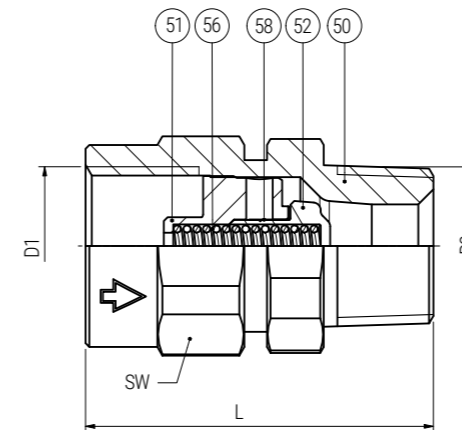
**Maßskizze measured sketch****Materialtabelle materials grid**

Nr. No.	Bezeichnung Description	Werkstoff Material	Materialbezeichnung Material description
50	Gehäuse Body	Stahl verzinkt Steel (zinc-plated)	1.0737
51	Stern Star	Messing Brass	CW617N
52	Schließkegel Closing cone	Stahl Steel	1.0737
56	Druckfeder Pressure spring	Federstahl Spring steel	1.4310
58	Lot Solder	Lot 95 Solder 95	-

